

Vickers®

Directional Controls



EMV-611e Electro-Hydraulic Mobile Control Valve

Flows to 160 l/min (42 USgpm) System Pressures to 320 bar (4600 psi)

EMA (Amplifier for EMV-611e)

Digital Electronics



This product has been designed and tested to meet specific standards outlined in the European Electromagnetic Compatibility Directive (EMC) 89/336/EEC, amended by 91/263/EEC and 92/31/EEC. For instructions on installation requirements to achieve effective protection levels, see this leaflet and the Installation Wiring Practices for Vickers Electronic Products leaflet 2468. Wiring practices relative to this Directive are indicated by  Electro Magnetic Compatibility (EMC)

Table of Contents

Introduction	3
EMV-611e Electro-Hydraulic Mobile Control Valve	
Features and Benefits	4
Model Description/Operating Data	5
Valve Sections/Model Codes	6
Flow Curves	8
Flow Curves/Functional Symbols	10
Installation Dimensions	11
EMA (Amplifier for EMV-611e)	
Features and Benefits/Model Code	12
General Description	13
Operating Data	14
Additional Data	15
Installation Dimensions	16
Application Data	17

Introduction

The EMV-611e is a sectional design electro-hydraulic mobile control valve with screw-in, pretested, preset individual control elements, allowing maximum flexibility in tailoring the valve to meet the needs of your specific application.

The EMV-611e allows for maximum machine productivity and high performance with rated flows to 160 l/min (42 USgpm) at 14 bar ΔP and pump pressures to 320 bar (4600 psi).

Designers have the opportunity to select fully flexible, optimum performance solutions for all machine types.

To compliment the EMV-611e, Vickers offers our own driver – the EMA Amplifier.

The EMA simplifies communications by interfacing directly with the EMV. The EMA can be driven directly from an Electronic Remote Control (ERC), PC or a Central Processing Unit (CPU).

The EMA is environmentally friendly and is built to withstand submersion in water and abuse or shock. It can withstand erroneous electronic signals in line with European legislation.

All backed by Vickers experience as the market leader in mobile controls.

Typical Electrohydraulic Valve Section

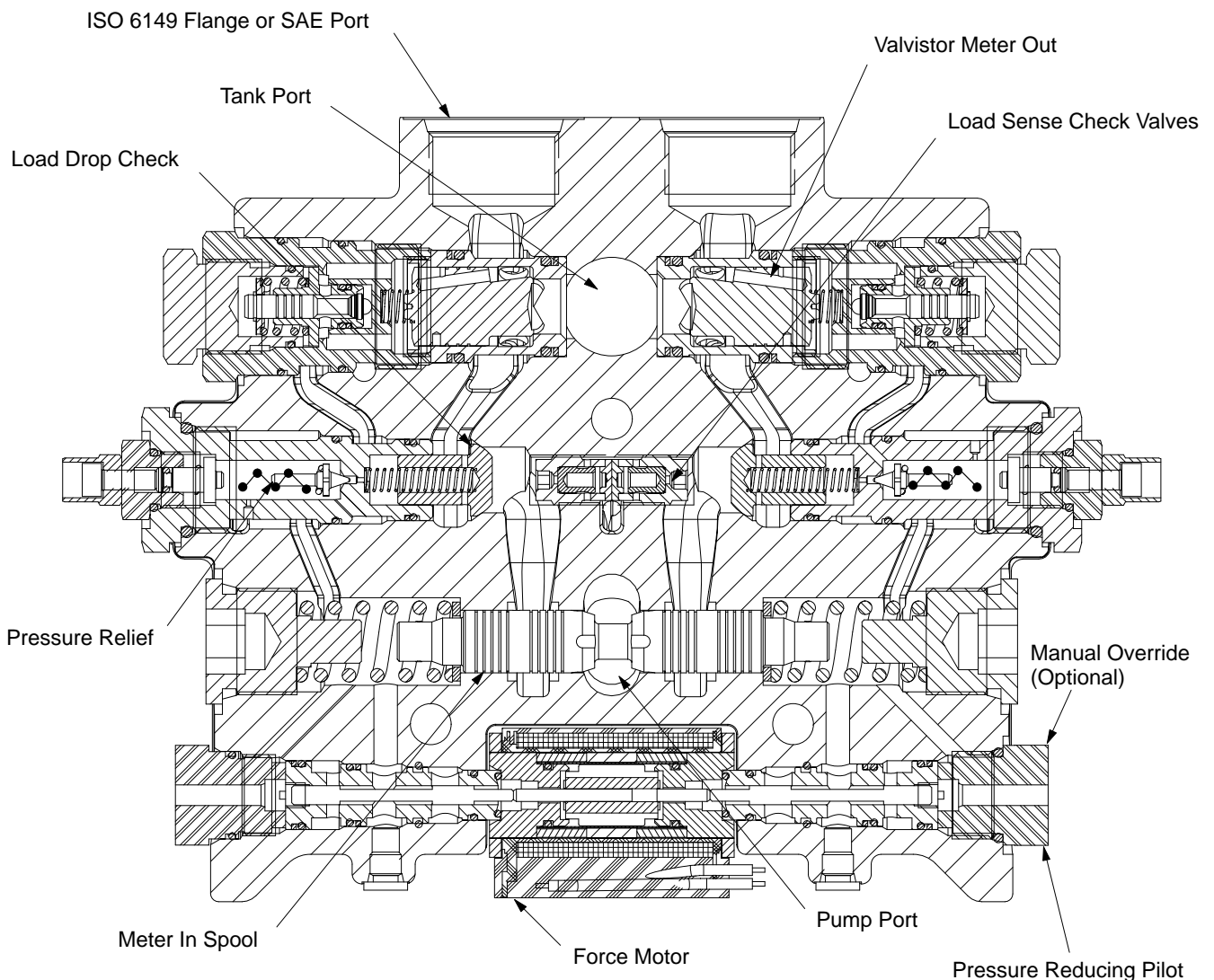

EMV-611e Electro-Hydraulic Mobile Control Valve

Features and Benefits

The EMV-611e offers the following features:

- **Easily Matched Performance to Need...**

Incorporates a Unibody with individual Meter-in and Meter-out elements such as different Meter-in/Meter-out flows to accommodate unequal ratio area cylinders. Cartridge valve design allows for easy installation/removal of load drop check and meter-out elements. This permits new designs to be rapidly prototyped.

OEM vehicle manufacturers can tailor their vehicle features by selecting those Meter-in/Meter-out elements necessary to meet their application needs.

- **At The Right Price...**

Installation and operating costs have been minimized. Individual valve elements are housed in a Unibody casting where overall system weight has been optimized.

The valve is actuated with a force motor instead of traditional high power solenoids. This means a smaller size and lower weight in a lower power consumption device. In addition, low operating power means simplification of amplification devices.

The force motor can be driven directly with a controller, eliminating redundant electronics or Vickers offers an EMA amplifier for use with an electronic remote control to drive the force motor.

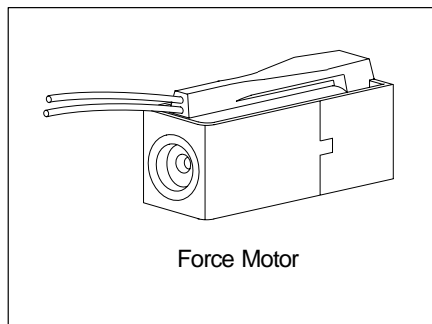

- **Using Advanced Simplicity...**

The EMV-611e incorporates revolutionary Valvistor® technology, proven around the world in applications demanding high performance proportional directional flow control without the need for expensive additional feedback devices.

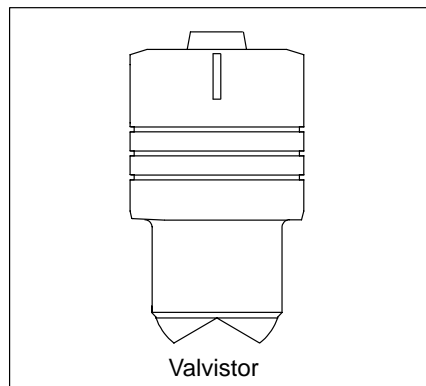

- **And Field-Proven Design...**

Meter-in and load drop elements have been developed with Vickers CMX technology, proven in the field for over a decade.

- **To Provide A Total Package...**

A full range of Electro-Hydraulic Mobile Valves (EMV) complete with Electronic Remote Control (ERC) and an EMA (amplifier) are just parts of the total product range available from Vickers. This “one-stop shopping” package eliminates the number of suppliers necessary to provide a total system solution.

- **With Increased Productivity & Energy Efficiency...**

Utilization of Computational Fluid Dynamics (CFD) to optimize flow paths and reduce pressure drop.

- **At Higher Pressures...**

Finite Element Analysis (FEA) is used to ensure that valve body can meet high pressure requirements.

- **While Still Environmentally Friendly.**

Environmentally friendly with optimized contact area between sections, resulting in a zero leakage product. Vickers also offers ISO 6149 port connectors to support zero product leakage.

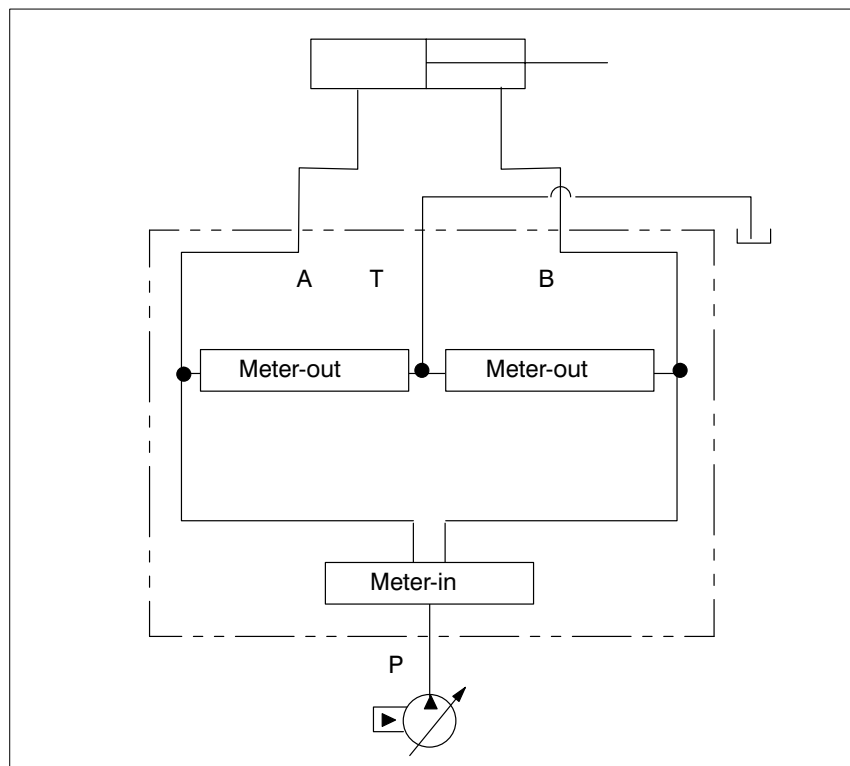

Model Description/Operating Data

General Description

The EMV is a sectional, load sensing proportional directional control valve, which can be operated by a CPU or via the Electro-Hydraulic Mobile Amplifier (EMA), driven by Electronic Remote Controls (ERC).

A major characteristic of the EMV valve line is the concept of separate meter-in and meter-out elements. The meter-in element is a pilot operated, pressure compensated proportional sliding spool, and controls fluid from the pump to the actuator.

The meter-out elements are pilot controlled metering poppets and control outlet flow from the actuator to the tank. Each meter-out poppet functions as a flow control between one of the actuator ports and the tank port, with the degrees of flow proportional to the pilot signal.

The separation of the meter-in and meter-out elements plus the modular design of the valve permits a broad range of control options to meet a variety of load requirements. This is especially desirable for a sectional mobile valve, where a single valve bank must handle different functions. The EMV can be designed to accommodate up to nine individual valve banks for added versatility.

The EMV section consists of three basic parts: the main valve body which contains the main flow passages and main control elements, and two control caps (end inlet & end cover) that contain the pilot circuitry.

Filtration Requirements

19/17/14

Temperature Limits

Minimum ambient: -30°C (-22°F)

Maximum ambient: +85°C (185°F)

Applications

- Loader backhoes
- Wheel loaders
- Asphalt/Concrete pavers
- Mobile drills
- Agricultural tractors/harvesters
- Motor graders
- Railroad maintenance
- All terrain cranes
- Truck loading cranes
- Rough terrain cranes/forklifts
- Refuse packers
- Underground boring
- Aerial work platforms
- Salt/Sand spreaders
- Mining roof bolters
- Forestry feller-bunchers

Operating Data

Pressure Limits bar (psi)	
Port	Limits
P	320 (4600)
A & B	350 (5000)
T	35 (500)
Additional Data	
Flow rating	160 l/min (42 USgpm) @ 14 bar ΔP
Types of Protection	
Force motor	IEC 144/Class IP67 (Dependant on connector)
Force motor winding	Class H
Force motor encapsulation	Class F
Relative duty factor	Continuous, ED=100%
Force Motor Characteristics	
Current	± 0.5A
Coil resistance	@ 20°C R=18 Ohm
Power	5W
EMA Amplifier Supply Voltage	0-24 VDC/1-12 VDC

Valve Sections/Model Codes

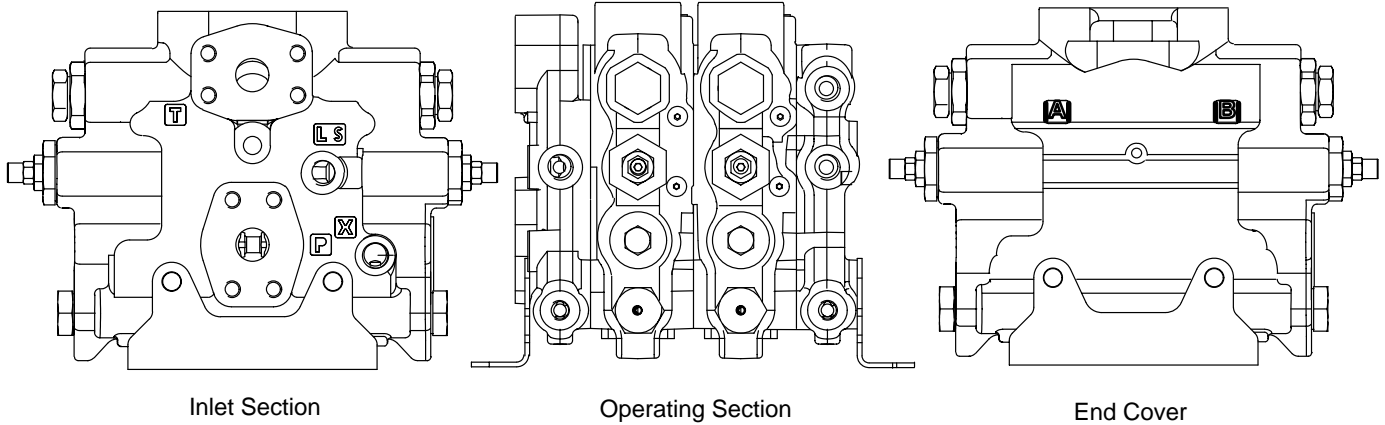

Inlet Section

EMV611e - 160 - M - M - E

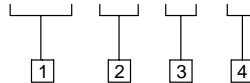

1 Valve Series

160

2 Port Connection

- M** - M33x2 ISO 6149 port
- S** - 1.3125-12 UN-2B SAE-16 port
- F** - 3/4" SAE flange port code 61
- G** - 3/4" SAE flange port code 62

3 Threads

- M** - Metric
- U** - Inch

4 Pilot Pressure

- E** - External
- N** - Internal

End Cover

EMV611e - 160 - M - X

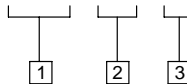

1 Valve Series

160

2 Port Connection

- M** - M33x2 ISO 6149 port
- S** - 1.3125-12 UN-2B SAE-16 port
- F** - 3/4" SAE flange port code 61
- G** - 3/4" SAE flange port code 62

3 Drain

- X** - External
- N** - Internal

Operating Section

EMV611e - 160 - M - A - V - S - R - 06 - 0 - 5 - 06 - 10 - R - 06 - 0 - 5 - 06 - 10 - P - P - DL - VA - 10

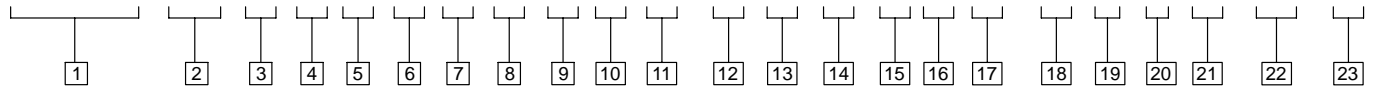

1 Model Series

EMV - Electro-Hydraulic Mobile Sectional Valve; flows to 160 l/min (42 USgpm); pressures to 320 bar (4600 psi); maximum sections: 9

2 Valve Series

160

3 Port Connection

M - M33x2 ISO 6149 port
S - 1.3125-12 UN-2B SAE-16 port
F - 3/4" SAE flange port code 61
G - 3/4" SAE flange port code 62
A - Anti-cavitation module

4 Module Options

A - Anti-cavitation, A side
B - Anti-cavitation, B side
C - Anti-cavitation, A and B-side
N - No anti-cavitation module

5 Seal Type

V - Viton®
N - Nitrile (standard)

® Viton is a registered trademark of E.I. DuPont

6 Section Type

S - Standard
F - Float (end section only)
L - Load Lowering Valve
C - Meter-out (Free Coast)

7 Optional Functions, A-Side

R - Standard Relief
D - Adjustable Relief
P - Meter-out Pressure Control
A - Anti-Saturation
E - Meter-in Pressure Limitation
N - No Relief Valve

8 Meter-in Flow, A-Side

06 - 60 l/min (16 USgpm)
10 - 100 l/min (26 USgpm)
16 - 160 l/min (42 USgpm)

9 Feedback Pin Diameter, A-Side

0 - No Feedback Pin
2 - Size 2
4 - Size 4
5 - Size 5

10 Meter-in Crack Pressure, A-Side

5 - 5 bar (75 psi) Standard
10 - 10 bar (150 psi)
5A - 5 bar (75 psi), Externally adjustable
10A - 10 bar (150 psi), Externally adjustable

11 Meter-out Flow, A-Side

06 - 60 l/min (16 USgpm)
06N - 60 l/min (16 USgpm), non-pressure compensation
10 - 100 l/min (26 USgpm)
10N - 100 l/min (26 USgpm), non-pressure compensation
16 - 160 l/min (42 USgpm)
16N - 160 l/min (42 USgpm), non-pressure compensation

12 Pressure Relief Setting, 10 Bar (150 psi) Increment, A-Side

10 - 100 bar (1500 psi)
35 - 350 bar (5000 psi)
00 - No relief

13 Optional Functions, B-Side

R - Standard Relief
D - Adjustable Relief
P - Meter-out Pressure Control
A - Anti-saturation
E - Meter-in Pressure Limitation
N - No Relief Valve

14 Meter-in Flow, B-Side

06 - 60 l/min (16 USgpm)
10 - 100 l/min (26 USgpm)
16 - 160 l/min (42 USgpm)

15 Feedback Pin Diameter, B-Side

0 - No Feedback Pin
2 - Size 2
4 - Size 4
5 - Size 5

16 Meter-in Crack Pressure, B-Side

5 - 5 bar (75 psi)
10 - 10 bar (150 psi)
5A - 5 bar (75 psi), Externally adjustable
10A - 10 bar (150 psi), Externally adjustable

17 Meter-out Flow, B-Side

06 - 60 l/min (16 USgpm)
06N - 60 l/min (16 USgpm), non-pressure compensation
10 - 100 l/min (26 USgpm)
10N - 100 l/min (26 USgpm), non-pressure compensation
16 - 160 l/min (42 USgpm)
16N - 160 l/min (42 USgpm), non-pressure compensation

18 Pressure Relief Setting, B-Side

10 - 100 bar (1500 psi)
35 - 350 bar (5000 psi)
00 - No relief

19 Manual Overrides, A- and B-Sides

P - Manual overrides, pilot push type
N - No overrides
S - Screw-type

20 Manual Overrides, Meter-out Valves

P - Manual overrides, pilot push type
N - No overrides
S - Screw-type

21 Voltage

DL - 10VDC

22 Electrical Connections

VA - Vickers Amplifier
FL - Flying Leads (No connector)
MP - Flying Leads with Metri-Pak connector

23 Design Number

10

Flow Curves

EMV Meter-in Metering

Meter-in metering for constant pressure drop of 14 bar (200 psi), 20 bar (300 psi) and 100 bar (1500 psi).
 L/min USgpm

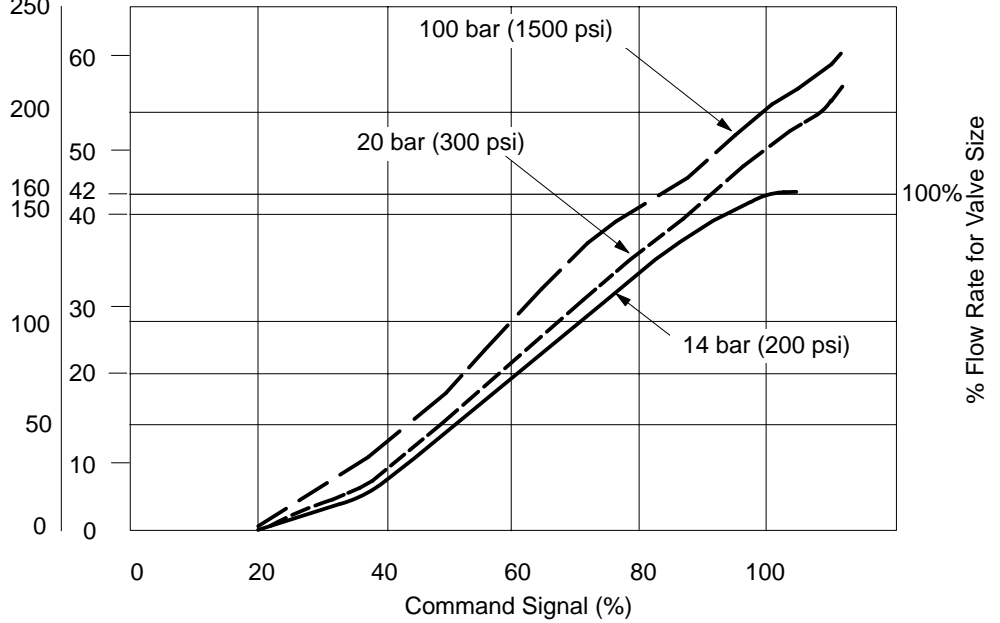

EMV Meter-out Metering

Meter-out metering for constant pressure drop of 14 bar (200 psi), 20 bar (300 psi) and 100 bar (1500 psi).
 L/min USgpm

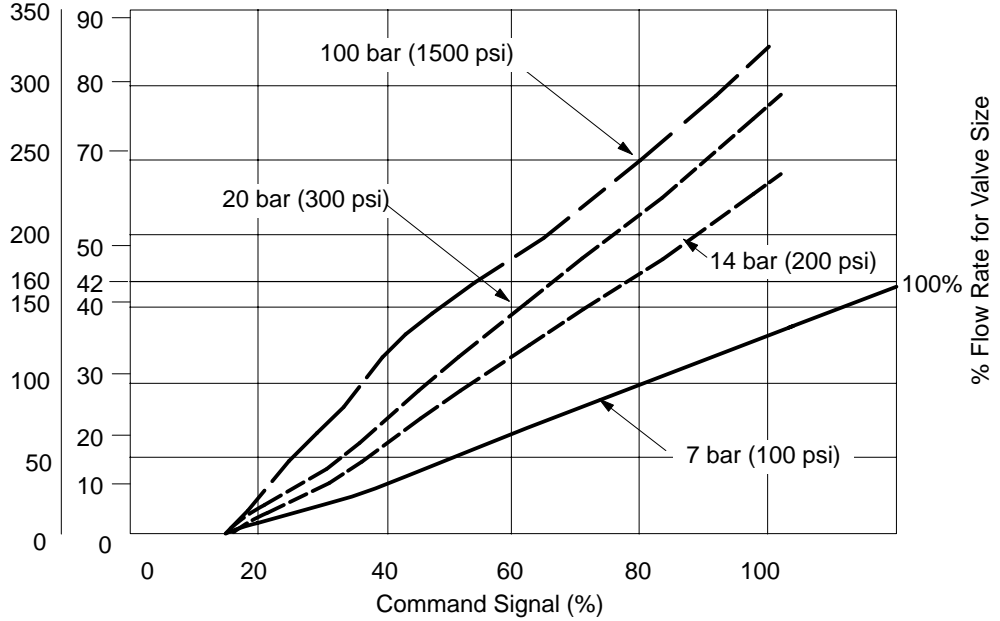

EMV Meter-in Pressure Compensation

Meter-in pressure compensation at 25, 37.5, 50, 61.5, 75, 87.5 and 100% command signal.

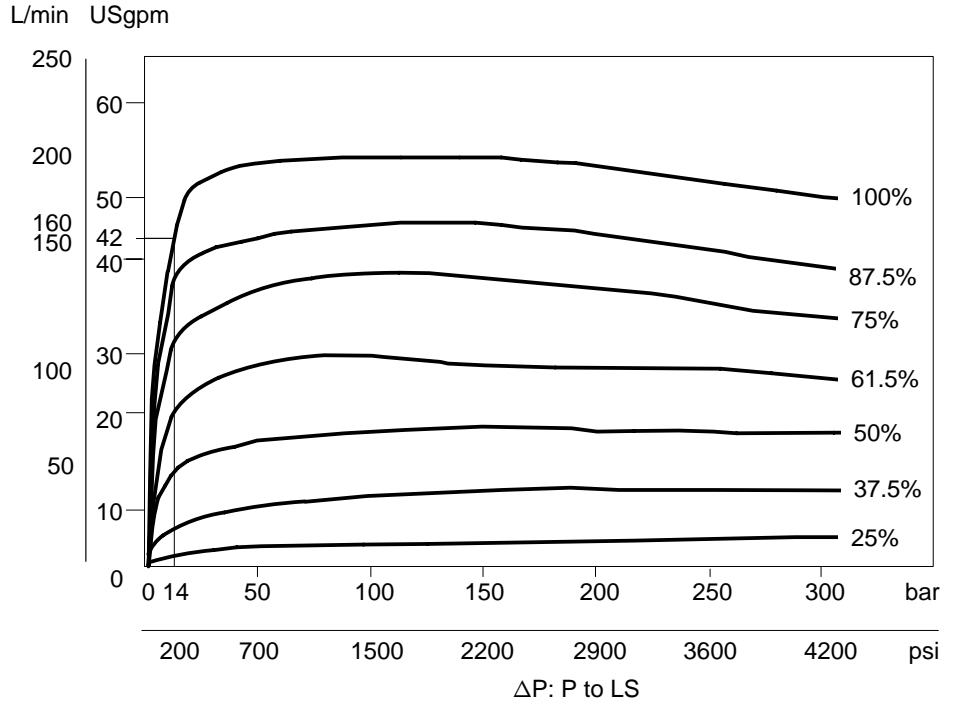

EMV Meter-out Pressure Compensation

Meter-out pressure compensation at 18, 25, 33, 45, 60, 80 and 100% command signal.

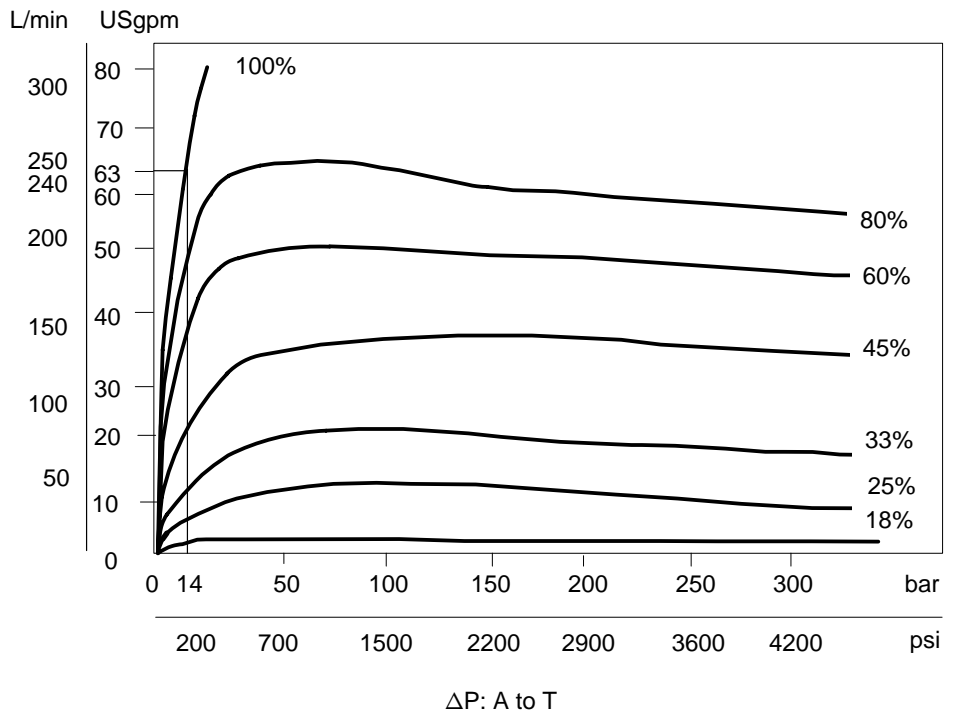

Flow Curves (continued)/Functional Symbols

EMV Metering @ 14 bar (200 psi) Pressure Drop

Meter-in and meter-out metering at constant pressure drop of 14 bar (200 psi) from P→LS and from motor port→tank.

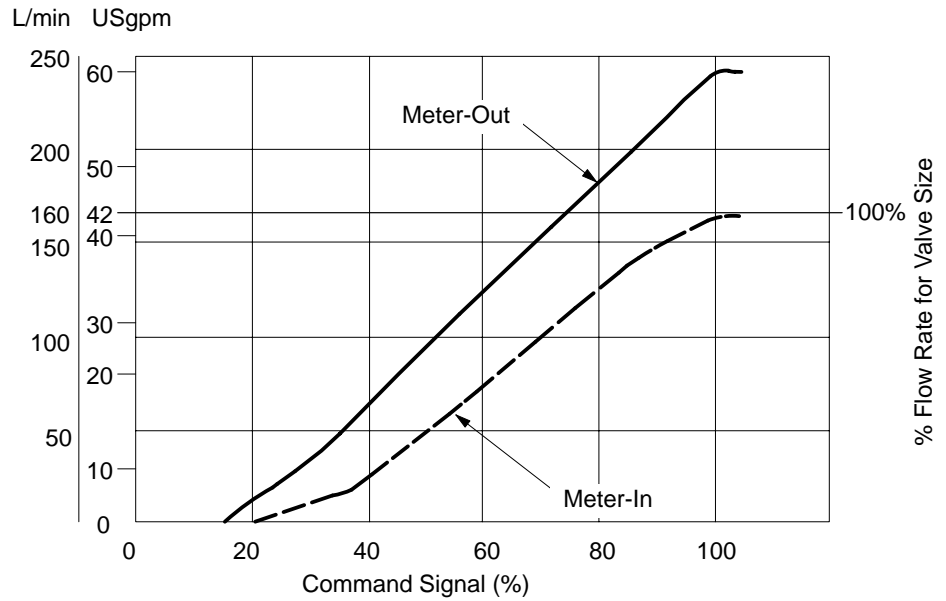

Functional Symbols

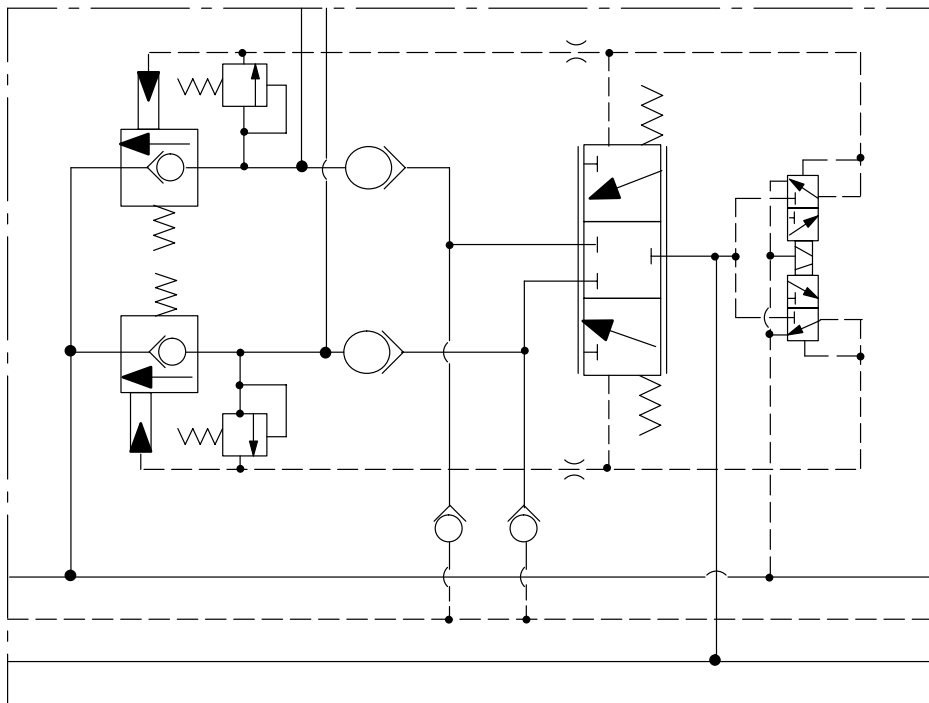

Installation Dimensions

Typical Valve Banks

Dimensions
mm (inches)

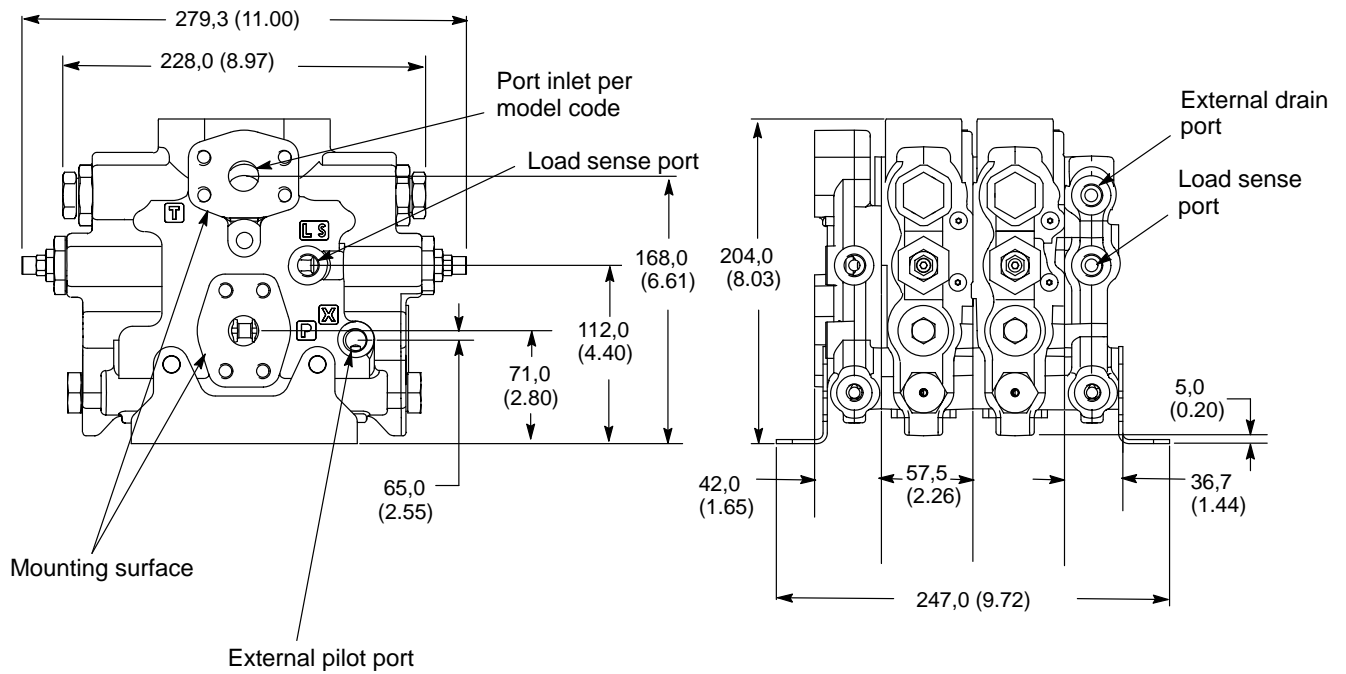
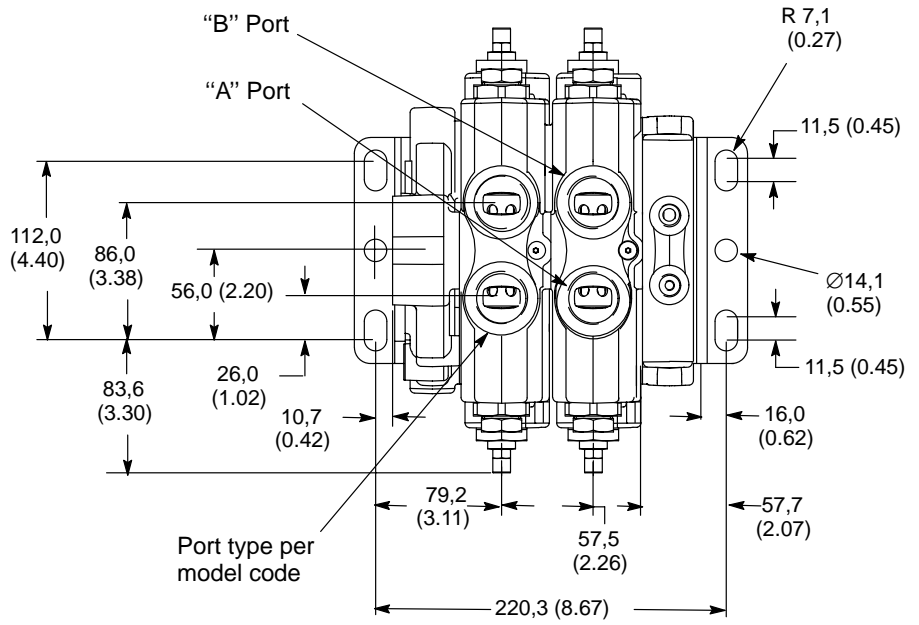

EMA (Amplifier for EMV-611e)

Features and Benefits

The EMA offers the following features:

- **Ease of Set-up:**

Amplifier setup is simplified with connection between the PC and amplifier using a serial link, which also loads the Vickers setup software. The software digitally sets ramp, deadband, gain and dither, which can be saved by a filename and easily recalled and used for various machine types.

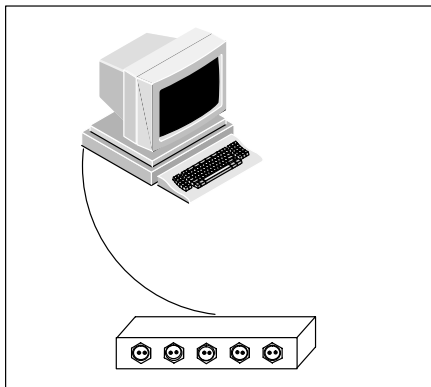

- **Environmentally Friendly:**

Amplifier is IP67 rated, meaning it can be mounted anywhere on the machine. It is 100% waterproof and can withstand temporary submersion in water, up to 30 minutes at 3 feet (< 1m).

- **Rugged Design:**

Amplifier is a die cast housing, built to withstand abuse and difficult positioning on machinery.

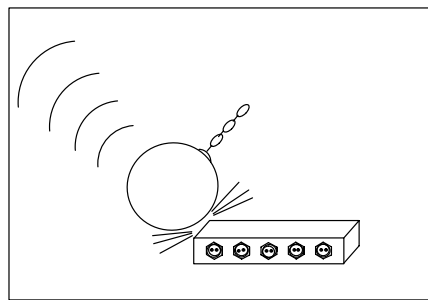

- **Simplified Diagnostics:**

Amplifier provides simple LED diagnostics in order to enable operator to check correct power levels and enable connections. This means that servicing, setup and commissioning are easy and simple.

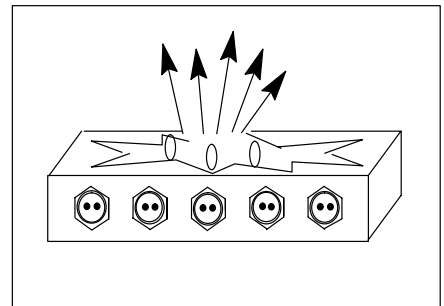

- **CE Approved:**

Rated to withstand erroneous signals from stray magnetic waves. Amplifier meets European legislation requirements.

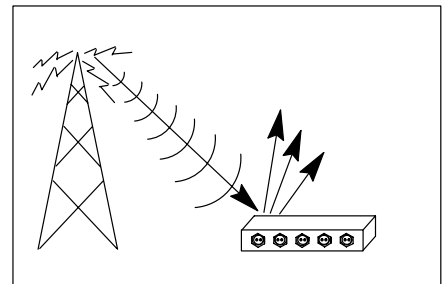

Model Code

EMA - P1 - 0 - C - 05 - S2 - 10

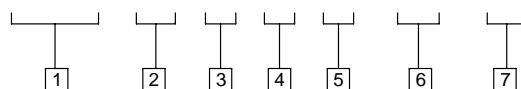

1 Model Series

EMA - Electro-Hydraulic Mobile Amplifier

2 Style

P1 - Box with M-12 connectors

3 Supply Voltage

0 - 24V
1 - 12V

4 Function

C - CAN Bus
I - 4-20mA
J - Joystick
V - 0-10V

5 Current Rating

05 - 500mA

6 Number of Sections

S2 - 2 sections
S3 - 3 sections
S4 - 4 sections

7 Design Number

10



This product has been designed and tested to meet specific standards outlined in the European Electromagnetic Compatibility Directive (EMC) 89/336/EEC, amended by 91/263/EEC and 92/31/EEC. For instructions on installation requirements to achieve effective protection levels, see this leaflet and the Installation Wiring Practices for Vickers Electronic Products leaflet 2468. Wiring practices relative to this Directive are indicated by Electro Magnetic Compatibility (EMC)

General Description

General Description

The EMA is a stand-alone amplifier capable of driving up to four sections of the EMV 611e. The EMA can receive up to four joystick inputs with an optional 0-10V or 4-20mA interface for CPU control.

The amplifier is a standard die-cast housing with a screw-on lid and a main printed circuit board which performs all amplifier functions.

The EMA is vibration and water proof allowing for use in any position.

The drive stage with 6 watt capability provides bidirectional current control with PWM based on MOS-FET power transistors which are surface mounted.

Additional features include:

- Supply voltage 12V and 24V, range according to SAE J1211
- Maximum current +/-600mA per section
- Disable
- Trap faults
- Bandwidth 30 Hz
- Ramp times 0-10 seconds
- Dither amplitude and frequency optimized for best performance of the force motor
- Step response
 - 0%-100% < 20ms
 - 100%-0% < 20ms
- Accuracy < 5%

Force Motor Drive Stages

The amplifier has 4 drive stages to drive the EMV force motors. The outputs are pulse width modulated current control, with a -500mA to +500mA to the force motors. The polarity of the solenoid current determines the activated port of the valve (A/B). The frequency of the pulse width modulation is optimized for the dither effect that gives minimum hysteresis in the valve and stable operation of the hydraulic system (140Hz). For the different requirements of the application of the PWM, frequency can be reduced to 70 Hz or increased to 240 Hz.

Adjustment

The amplifier settings can be adjusted via the serial link or a CAN-Bus connection. The parameters are stored in a non-volatile memory and restored after power is supplied to the amplifier.

CAN Bus Version

All values are set using the bus system and are stored in non-volatile memory. Status and diagnostics can be read using the bus system. Parameters such as ramp times and gain can be changed to alter the performance of the valve.

Electronics are microprocessor controlled. Four power outputs with current and polarity control are used for the force motors.

Bus Protocol Software

Simple protocol software fully supports all functions of the amplifier, sets commands, parameters and diagnostics. The amplifier, valve and CAN-Bus can be tested with master software, provided for an IBM-PC plug-in card or a printer port to the CAN-Bus converter.

Serial Link

Amplifiers without the CAN-Bus option will be set via serial link. The link uses the same connectors as the CAN-Bus connection. With this interface, the amplifier can be connected to a PC.

Amplifier Setup Software

Simple Windows-based software fully supports all functions of the amplifier. The amplifier sets parameters and command and shows status and diagnosis. Parameters can be downloaded from PC to amplifier and uploaded from the amplifier to the PC and stored in a file.

PLC Interface

If a PLC has to drive the amplifier, a 0 to 10V and 4 to 20mA interface are available. These versions use the joystick connector for command input.

Operating Data

Power Supply	
24 Volt Version	Range
Nominal supply voltage	24V
Supply voltage range	19V-32V (include 10% ripple)
Supply voltage for max. current	24V
12 Volt Version	
Nominal supply voltage	12V
Supply voltage range	9V-16V (include 10% ripple)
Supply voltage for max. current	12V
Common Data	
Item	Comments
Size (approx.)	150 x 65 x 35mm (6 x 2.5 x 1.4 in.)
Load dump protection	150 VDC-500 Hz (with external fuse)
Abs. max. voltage	72V (less than 1,5 ms)
Fuse: 4 section version	4A fast (necessary for load dump protection)
Max.power consumption including solenoid (one solenoid energized)	45W
Reverse polarity protected	No (external fuse needed)
Short circuit protected	Yes
Output current per solenoid: rated	0.5A
Output current per solenoid: max.	0.8A
Max.output voltage	23V (24V supply)
Nominal supply voltage @ 0.5A output current	11V (12V supply, typical 1V below supply voltage)
Deadband compensation	0%-50% of maximum current
Trigger level for deadband	1%-10% of maximum input command
Gain	0%-110% of max. current
Ramp time	20ms - 10s (4 quadrants)
PWM frequency	70/140/280Hz
Dither frequency	-PWM
Joystick resistance	Minimum 5 k Ω (0,3 watt maximum power dissipation)
Joystick operating range	5% - 95% (for joystick cable diagnostic)
Serial link logic levels	-12V +12V (RS 232 standard)
Serial link baud rate	9600 baud
Vickers Environmental Specification	Class II (product for mobile market)
Electro-magnetic compatibility (EMC): emission	EN-50081-2
EMC: immunity	EN-50082-2
ASAE-Standard	EP455 Level 2 (pressurized cabs)
Operating temperature range	-30°C to +85°C (-28°F to +185°F)
Storage	-40°C to +85°C (-40°F to +185°F)
Connector type	M12-female 4-pole for supply, serial link sections/M12-male 8-pole for joysticks
Mechanical vibration	0.54mm (10 - 55Hz)/5g (55Hz - 20kHz)
Protection class	IP 67 (IEC 529)
Housing material	Die cast aluminum
Digital in- and Outputs	
24V Supply Version:	
Switching inputs voltage level	-3V to 5V (off)/13V to 30V (on)/5V to 13V (signal at previous level – hysteresis)
12V Supply Version:	
Switching inputs voltage level	-3V to 3V (off)/7V to 30V (on)/3V to 7V (signal at previous level – hysteresis)

Additional Data

Joystick Interface

A special M12 connector is available for 4 analogue joysticks. All joysticks have to be connected together with one cable/plug. Single/double or triple axis joysticks can be used. The amplifier will supply the reference voltage of 15V for

the 24V version and 8V for 12V version. The range of reference voltage will be supervised by the microprocessor and it is short circuit protected.

The table below shows when joystick handling from a mobile amplifier is used.

Input voltage % of reference	Action
0-5%	Cable break/short detect
5-45%	100% to 0% flow at Port A
45-55%	Deadband trigger range - output drive off
55-95%	0% to 100% flow on Port B
95-100%	Cable break/short detect

Connectors

Position	Type	Signals
Supply	M12 Male 4-pole	1- 24V Power 2- 0V Power 3- Ready 4- Enable
Serial Link		1- CAN- /Serial receive 2- CAN+ /Serial send 3- Gnd 4- Not connected
Section 1/2		1- Forcemotor Section 1+ 2- Forcemotor Section 1- 3- Forcemotor Section 2+ 4- Forcemotor Section 2-
Section 3/4		1- Forcemotor Section 3+ 2- Forcemotor Section 3- 3- Forcemotor Section 4+ 4- Forcemotor Section 4-
Joysticks	M12 Female 8-pole	1- +15V Joystick supply 2- 0V Return 3- Input Joystick Section 1 4- Input Joystick Section 2 5- Input Joystick Section 3 6- Input Joystick Section 4 7- Not connected 8- Shield/Protective Earth

Installation Dimensions

Dimensions
mm (inches)

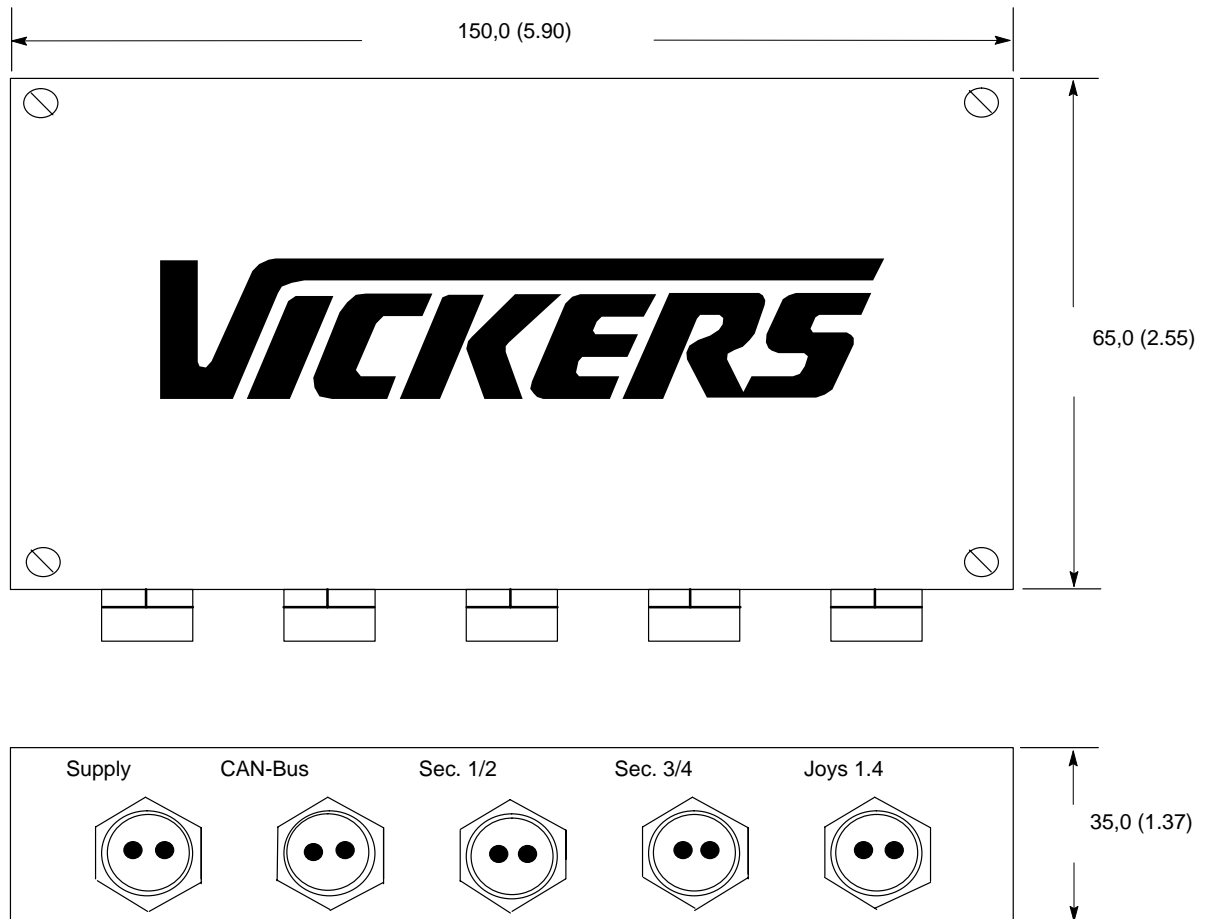

Application Data

Fluid Cleanliness

Proper fluid condition is essential for long and satisfactory life of hydraulic components and systems. Hydraulic fluid must have the correct balance of cleanliness, materials, and additives for protection against wear of components, elevated viscosity, and inclusion of air.

Essential information on the correct methods for treating hydraulic fluid is included in Vickers publication 561 "Vickers Guide to Systemic Contamination Control" available from your local Vickers distributor or by contacting Vickers, Incorporated. Recommendations on filtration and the selection of products to control fluid condition are included in 561.

Recommended cleanliness levels, using petroleum oil under common conditions, are based on the highest fluid pressure levels in the system and are coded in the chart below. Fluids other than petroleum, severe service cycles, or temperature extremes are cause for adjustment of these cleanliness codes. See Vickers publication 561 for exact details.

Vickers products, as any components, will operate with apparent satisfaction in fluids with higher cleanliness codes than those specified. Experience has shown, however, that life of any hydraulic component is shortened in fluids with higher cleanliness codes than those listed below. These codes have been proven to provide a long, trouble-free service life for the products shown, regardless of the manufacturer.

Fluids and Seals

Nitrile seals are standard and are suitable for use with water glycol, water-in-oil emulsion fluids and petroleum oil.

Product	System Pressure Level bar (psi)		
	<70 (<1000)	70-210 (1000-3000)	210+ (3000+)
Vane Pumps – Fixed	20/18/15	19/17/14	18/16/13
Vane Pumps – Variable	18/16/14	17/15/13	
Piston Pumps – Fixed	19/17/15	18/16/14	17/15/13
Piston Pumps – Variable	18/16/14	17/15/13	16/14/12
Directional Valves	20/18/15	20/18/15	19/17/14
Pressure/Flow Control Valves	19/17/14	19/17/14	19/17/14
CMX Valves	18/16/14	18/16/14	17/15/13
Servo Valves	16/14/11	16/14/11	15/13/10
Proportional Valves	17/15/12	17/15/12	15/13/11
Cylinders	20/18/15	20/18/15	20/18/15
Vane Motors	20/18/15	19/17/14	18/16/13
Axial Piston Motors	19/17/14	18/16/13	17/15/12
Radial Piston Motors	20/18/14	19/17/13	18/16/13

Notes

Notes

Eaton Hydraulics
15151 Highway 5
Eden Prairie, MN 55344
Telephone: 612 937-7254
Fax: 612 937-7130
www.eatonhydraulics.com

46 New Lane, Havant
Hampshire PO9 2NB
England
Telephone: (44) 170-548-6451
Fax: (44) 170-548-7110

