

Service Data

Vickers®

Vane Pumps



High Pressure, High Performance Double Vane Pump

3525VPF Series -21 Design

OUT OF PRINT

To reverse Cartridge rotation remove Retaining Ring and Bearing Carrier S/A. Install Bearing Carrier S/A and Retaining Ring in opposite end of Cartridge and reinstall Cartridge facing in opposite direction. For R.H. rotation the end of the Cartridge with screw heads showing will be installed toward the cover end. For L.H. rotation the end of the Cartridge with screw heads showing will be installed toward the shaft end.

Model Code (Cover End)	● Cartridge Kit Standard	● Cartridge Kit Viton®
3525VPF-010	02-319101	02-319102
3525VPF-016	02-319103	02-319104
3525VPF-025	02-319105	02-319106
3525VPF-032	02-319107	02-319108
3525VPF-040	02-319109	02-319110
3525VPF-050	02-319111	02-379112
3525VPF-063	02-319113	02-319114
3525VPF-071	02-319115	02-319116
3525VPF-080	02-319117	02-319118

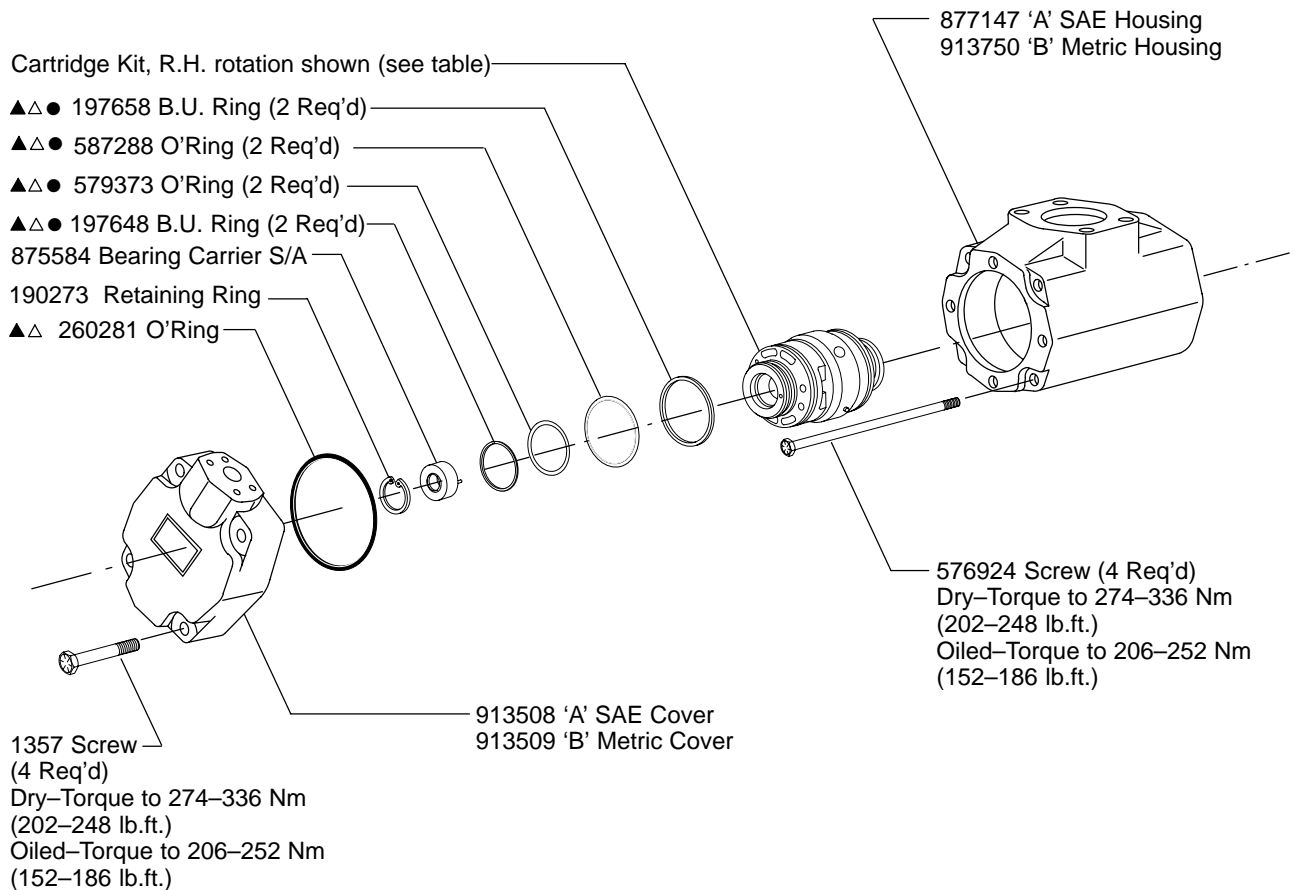

Parts prefixed with symbols are available only in kits.

▲ Available in 02-160542 Std Seal Kit, Single Shaft Seal or 02-160543 Viton® Seal Kit, Single Shaft Seal only.

△ Available in 02-160544 Std Seal Kit, Double Shaft Seal or 02-160545 Viton® Seal Kit, Double Shaft Seal only.

★ Included in Flange Kits (see table).

● Included in Cartridge Kits (see table).

Viton® is a registered trademark of the E.I. DuPont Co.

NOTE: Lubricate all parts and seals with a thin coat of oil at assembly.

Shaft Seal Options

A – Primary seal only: spring loaded sealing member facing inward.

B – Primary and secondary seals: primary seal with spring loaded sealing member facing inward and secondary seal with spring loaded sealing member facing outward.

C – Primary and secondary seals: both with spring loaded sealing member facing inward.

Model Code (Shaft End)	● Cartridge Kit Standard	● Cartridge Kit Viton®
3525VPF-090-***	02-322011	02-322012
3525VPF-100-***	02-322013	02-322014
3525VPF-112-***	02-322015	02-322016
3525VPF-125-***	02-322017	02-322018
3525VPF-135-***	02-322019	02-322020

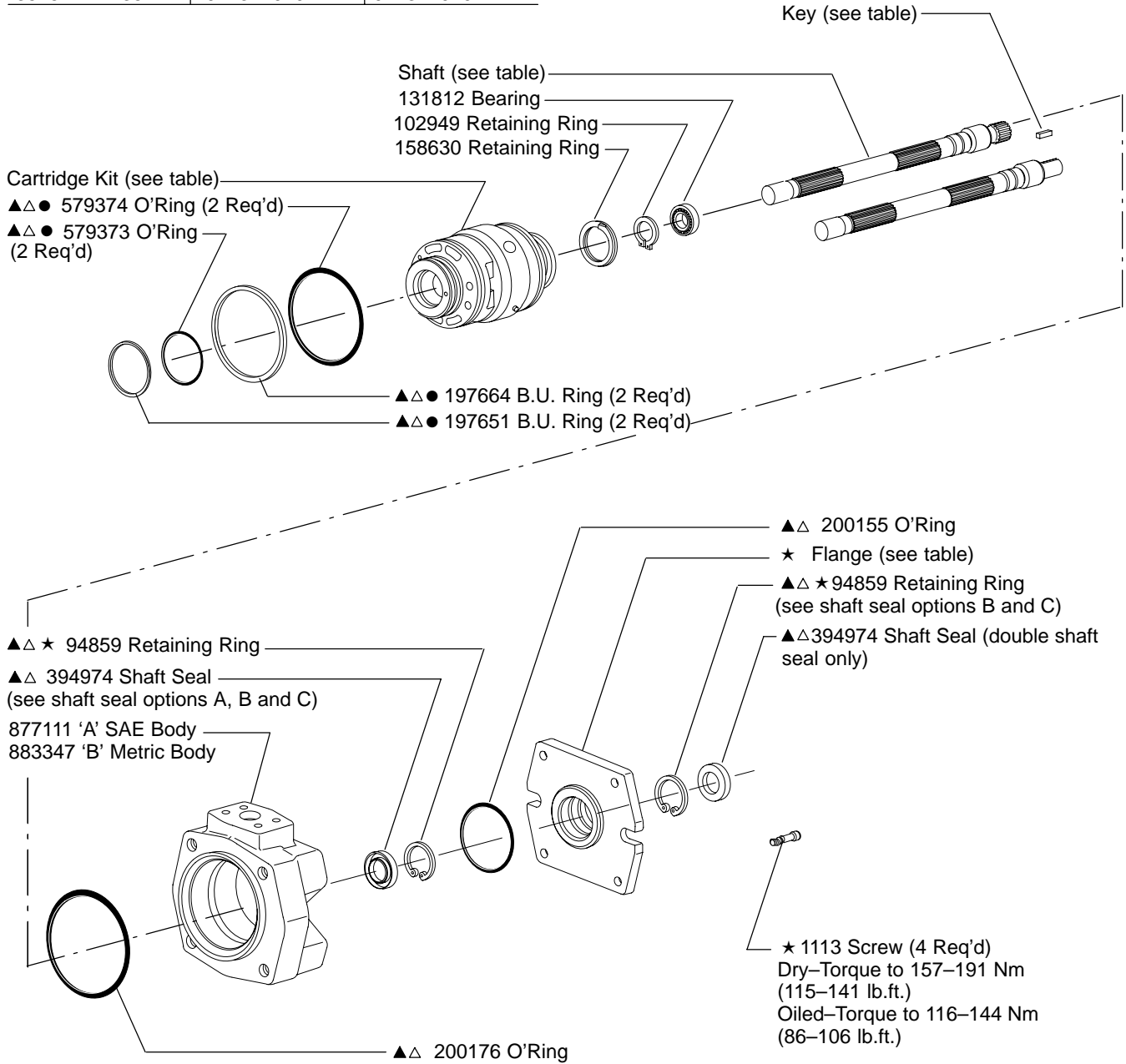

Flange Type	★ Flange Kit	
	Single Shaft Seal	Double Shaft Seal
SAE J744-127-2 (SAE C)	02-142488	02-142491
ISO 3019/2-125A2HW	02-142489	02-142492
SAE J744 152-2 (SAE D)	02-142487	02-152288
ISO 3019/2-160A2HW	02-142490	02-142493

Model Code	Shaft	Key
3525VPF-***-***-**-01	913744	928541
3525VPF-***-***-**-02	913699	—
3525VPF-***-***-**-03	913745	928546
3525VPF-***-***-**-05	913747	928542
3525VPF-***-***-**-06	877148	—
3525VPF-***-***-**-07	913748	928547

Eaton Hydraulics

15151 Highway 5
Eden Prairie, MN 55344
Telephone: 612 937-7254
Fax: 612 937-7130
www.eatonhydraulics.com

46 New Lane, Havant
Hampshire PO9 2NB
England
Telephone: (44) 170-548-6451
Fax: (44) 170-548-7110

